

The Saddle Powerbox was designed to have a narrow open for both clamps so the user can only slide in the dovetail and not place it on top as this isn't safe for many reasons.

Some customers can bypass this safety, so the following guide will allow the user adjust both clamps to be wider so the dovetail can also be placed from the top.

The procedure is straightforward, so you need the following tools:

1.3mm Allen hex key

2mm Allen hex key

6mm Allen hex key

Use the 1.3mm Allen hex key to untie and remove the lid

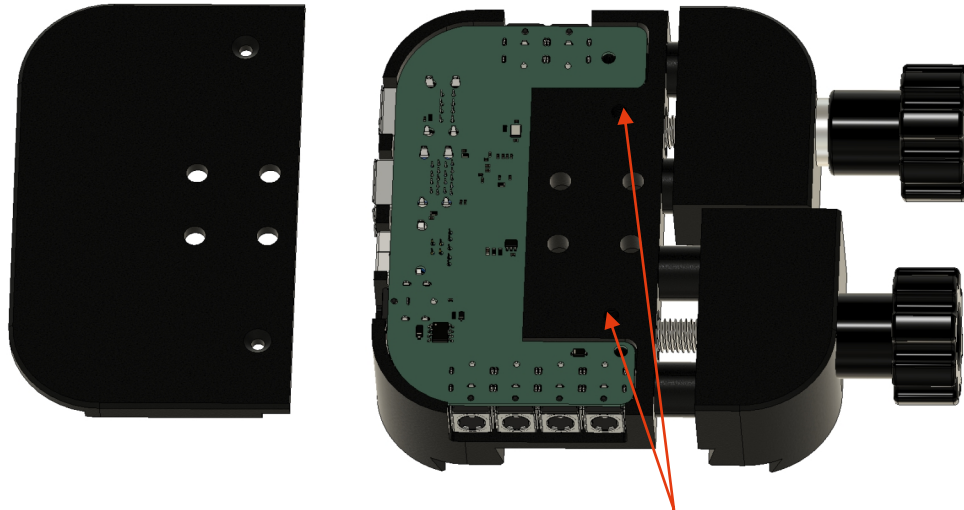

Use a 2mm Allen hex key to untie the set screws that are holding the M8 bolts

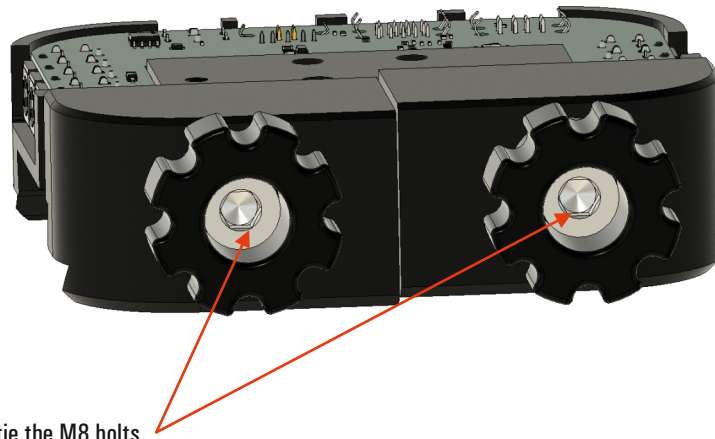

Use a 6mm Allen hex key to untie the M8 bolts.

While you untie the M8 bolt you should see that the clamp is moving back as the spring pushes it, so a distance of 10mm is fine. Now test your dovetail if it fits and tighten back everything.

